

Audio Functionality

- Choice of speech encoded on downlink TCH: none, echo, 300 Hz sine, 1 kHz sine, 3 kHz sine, PRBS-15, multi-tone, or custom
- GSM analog audio measurement (audio level, distortion, frequency, SINAD)

Receiver Measurements

- GSM bad frame indication (BFI)
- GSM FACCH frame erasure rate (FER)
- GSM burst-by-burst bit error ratio (fast BER)
- GSM bit error ratio (BER)
- (E)GPRS multislot bit error ratio (BER)
- (E)GPRS multislot block error ratio (BLER)
- AMR in-band frame error (AMR I-FER)
- USF BLER (assigned)
- USF BLER (unassigned)

Transmitter Measurements

(Maximum of two uplink timeslots)

- Multislot transmit power
- EGPRS multislot-tolerant modulation accuracy (peak, rms, 95th percentile and sample EVM; frequency, magnitude, and phase errors; origin offset suppression; and IQ imbalance)
- GSM/GPRS multislot-tolerant frequency error
- GSM/GPRS multislot-tolerant phase error (peak and rms with confidence limits)
- Multislot-power versus time (burst mask comparison with settable masks)
- Burst timing
- Multislot-tolerant output RF spectrum due to modulation and switching
- IQ tuning
- GSM decoded audio level
- Dynamic power
- Frequency stability
- Enhanced measurement reports
- Packet enhanced measurement reports
- 3G neighbor SACCH measurements

Instruments

- Audio generator
- General-purpose spectrum monitor
- Data throughput monitor
- GSM multi-tone audio

Protocol Functionality

- Dual transfer mode (DTM)
- 2-cell handovers and cell (re)selection (using two instruments)
- (E)GPRS PS data channel
- GSM CS data channel
- Frequency hopping on TCH or PDTCH
- AMR voice echo
- Highly configurable GSM and (E)GPRS SMS
- RRLP layer for A-GPS and E-OTD
- Protocol event trigger outputs
- Protocol logging with WPA software
- SACCH and PACCH measurement reports

| Call Setup Screen | | | | | | | | | | | |
|---------------------|---------------------------------|------|------------------|--------|------|------------------|--------|----------------|--|---------------------|--|
| SACCH Reports | SACCH Measurement Reports | | | | | | | Call Params | | | |
| General | Report Type: NORMAL | | | | | | | BCH Parameters | | | |
| | Serving Cell Reports | | | | | | | TCH Parameters | | | |
| Enhanced Neighbours | Timing Advance: | 0 | | | | | | | | PDTCH Parameters | |
| | Tx Level: | 15 | (13 dBm) | | | | | | | Handover Parameters | |
| | Rx Level (Full): | 47 | (-64 to -63 dBm) | | | | | | | | |
| | Rx Level (Sub): | 47 | (-64 to -63 dBm) | | | | | | | | |
| | Rx Qual (Full): | 0 | << 0.2 % BER | | | | | | | | |
| | Rx Qual (Sub): | 0 | << 0.2 % BER | | | | | | | | |
| | Neighbour Cell Reports | | | | | | | | | | |
| | Cell | RAT | (U)ARFCN | NCC | BCC | SC | Report | Quantity | | | |
| | 1 | GSM | 20 | 1 | 5 | ---- | 47 | Rx Lev | | | |
| | 2 | ---- | ---- | ---- | ---- | ---- | ---- | ---- | | | |
| | 3 | ---- | ---- | ---- | ---- | ---- | ---- | ---- | | | |
| | 4 | ---- | ---- | ---- | ---- | ---- | ---- | ---- | | | |
| | 5 | ---- | ---- | ---- | ---- | ---- | ---- | ---- | | | |
| | 6 | ---- | ---- | ---- | ---- | ---- | ---- | ---- | | | |
| Return | Active Cell Connected/Suspended | | | | | Sys Type: GSM | | | | | |
| | | | | | | Logging: No Conn | | | | | |
| | | | IntRef | Offset | L | | | | | | |
| | | | | | | | | | | | |

Figure 1. Verify your EGPRS device's performance under various levels of downlink corruption with incremental redundancy.

2-Cell Handovers and Cell (Re-)Selection

Test handovers and cell (re-)selection from one fully configured instrument to a second instrument. IP data is automatically re-routed, enabling real service testing such as WAP, PoC, DTM, or email download during cell transitions.

Cell transition types supported

- Idle mode cell (re-)selection – MS initiated
- Idle mode cell (re-)selection – network initiated
- (E)GPRS packet transfer mode cell (re-)selection – MS initiated
- (E)GPRS packet transfer mode cell (re-)selection – network initiated
- GSM dedicated mode (voice) handover – network initiated
- GSM circuit switched data (CSD) handover – network initiated
- Dual transfer mode (DTM) handover – network initiated
- Idle mode cell selection

Each cell retains individual settings, for example

- Cell identification (MCC, MNC, LAC, RAC, NCC, BCC)
- Cell settings, DTM on/off, network control order, frequency hopping on/off, etc.
- Cell type, GSM, GSM+GPRS, GSM+EGPRS
- RF settings, MS Tx level, BCH ARFCN, (PD)TCH ARFCN cell power, multi-slot configurations, etc.

Both cells (instruments) can run individual measurements or measurement suites

- Spectrum monitor
- IP data throughput monitor
- All applicable Tx and Rx measurements, counters, and reports

Wireless Protocol Advisor (E6584A) supplied with E6701E updated to log all layers from decoded L1 to IP for both cells in a single log file.

The DUT IP address will be supplied from the instrument initiating the connection between the two instruments.

Primary DNS server address and secondary DNS server address will be supplied by the instrument to which the DUT is connected when the PDP context is started.

Each instrument retains its own individual IP address and GPIB address.

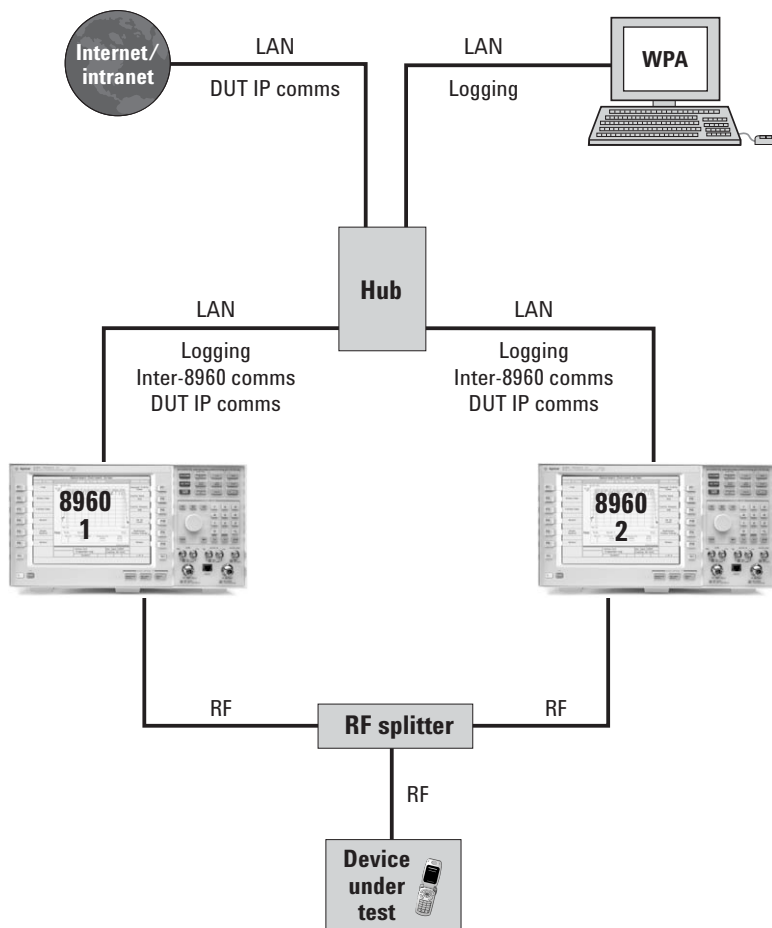

Figure 2. 2-Cell handover/cell (re-)selection test setup.

Dual Transfer Mode (DTM)

Simultaneous GSM circuit switched voice call and (E)GPRS data connection using contiguous timeslots on the same ARFCN.

- Cell operation setting, DTM on or off
- Enhanced DTM on or off
- DTM operable with active cell settings GPRS or EGPRS
- DTM circuit switched MS Tx level settable from 0 to 31
- Selectable DTM circuit switched timeslot position
- Downlink timeslot count of 2, 3, 4, or 5
- Uplink timeslot count of 2, 3, or 4
- Active cell indicators:
 - Connected/Attaching
 - Connected/Attached
 - Connected/Detaching
 - Connected/PDP active
 - Connected/Transfer
 - Connected/Starting
 - Connected/Ending
 - Connected/Idle
- GPRS and EGPRS DTM multislot class report display
- Additional limited signaling operating modes
 - GPRS BCH+PDTCH+TCH
 - EGPRS BCH+PDTCH+TCH

GSM and (E)GPRS Frequency Hopping

Applies to a traffic channel, TCH or PDTCH. The following settings can be changed when Cell Off operating mode is selected.

- **Cell allocation (CA) table:** 1 to 16 settable traffic channel ARFCN(s) to be used within the cell
- **Mobile allocation (MA) configuration:** selection of manual (user configures MA table entries) or auto (automatically enable every applicable entry in the CA table)
- **MA table:** 1 to 16 entries settable to indicate which entries within the CA table are used for hopping

The following settings can be changed at any time.

- **Mobile allocation index offset (MAIO):** settable between 0 and 15
- **Hopping sequence number (HSN):** settable between 0 and 63; 0 corresponds to a cyclic hopping sequence, 1 to 63 correspond to a pseudo-random hopping sequence
- **Measurement ARFCN:** settable measurement frequency based on valid entries in the MA table

AMR Voice Echo

- Make MO and MT calls with speech received by the test set looped back to the mobile
- Use stress mode to force the mobile to change codec mode on the uplink as often as allowable
- MS request option configures instrument to respond to mobile requests for codec rate changes
- In call changes of codec set, threshold or hysteresis values via RATSCCH signaling
- Current downlink and uplink AFS codec mode selectable as 4.75 kHz, 5.15 kHz, 5.9 kHz, 6.7 kHz, 7.4 kHz, 7.95 kHz, 10.2 kHz, 12.2 kHz, or stress mode
- Current downlink and uplink AHS codec mode selectable as 4.75 kHz, 5.15 kHz, 5.9 kHz, 6.7 kHz, 7.4 kHz, 7.95 kHz, or stress mode

The following settings can be changed.

- Logical speech channel setup selectable as half rate (HR), full-rate (FS), enhanced full-rate (EFS), adaptive full-rate (AFS), half-rate (HS), or adaptive half-rate (AHS)
- **AFS codec set:** one to four codecs selectable as 4.75 kHz, 5.15 kHz, 5.9 kHz, 6.7 kHz, 7.4 kHz, 7.95 kHz, 10.2 kHz, or 12.2 kHz
- **AHS codec set:** one to four codecs selectable as 4.75 kHz, 5.15 kHz, 5.9 kHz, 6.7 kHz, 7.4 kHz, or 7.95 kHz
- **Threshold values:** zero to three AFS threshold values or zero to three AHS threshold values are settable between 0 and 31.5 dB in 0.5 dB steps; number of threshold values settable is dependent on number of selected codec modes in the AFS or AHS codec set
- **Hysteresis values:** one to three AFS hysteresis values or one to three AHS hysteresis values are settable between 0 and 7.5 dB in 0.5 dB steps; number of threshold values settable is dependent on number of selected codec modes in the AFS or AHS codec set

GSM and (E)GPRS SMS

Test WAP push, MMS, EMS messaging, and concatenated SMS with expanded GSM and (E)GPRS SMS functionality.

Use the 8960's HTTP SMS interfaces to connect via Ethernet to a SMS gateway using industry standard protocols. Use tools provided by the SMS gateway to automate message configuration and content generation for all types of MT SMS messages. Two instruments can be linked via SMS gateway to enable phone to phone MMS test.

MT point-to-point SMS

- Determine the state of the last MT message sent as either idle, send, ack, nack, or reject
- Choose to send either GSM or (E)GPRS SMS
- Send UCS2 and binary MT SMS configured using a custom data GPIB command or send one of two fixed ASCII text messages or configure a custom ASCII text message using GPIB (TP-UD)
Fixed message 1:
0123456789ABCDEFGHIJKLMN
OPQRSTUVWXYZabcdefghijklmnopqrstu
vwxyz
Fixed message 2: Agilent Technologies, your partner in wireless solutions
- Configure the message type of any MT SMS as SMS-DELIVER, SMS-SUBMIT-REPORT, or SMS-STATUS-REPORT with the option to configure the SMS-SUBMIT-REPORT as RP-ERR (negative) or RP-ACK (positive)

MO point-to-point SMS

- Choose to receive either GSM or (E)GPRS SMS
- Loop back MO SMS to the mobile as a new message
- View on the test set's display all types of MO SMS received, including header content, as an ASCII string or string of hexadecimal characters
- Determine the header content of any MO SMS using GPIB queries for TP-DA, TP-DL, TP-DCS, TP-UDHI, TP-PID, TP-SRR, and TP-MR
- Determine the content of any MO SMS including header content and length, filler data, and message content using GPIB queries
- Determine when MO SMS has been received by the test set using GPIB interrupt or polling mechanisms
- **SMS-SUBMIT-REPORT:** respond automatically to an MO SMS or manually construct report and report type (RP-ACK or RP-ERR) and send when desired using GPIB
- **SMS-STATUS-REPORT:** send automatically when requested by the mobile in an MO SMS or manually construct and send when desired using GPIB
- Be sure to capture all concatenated MO SMS by using message queuing

GSM cell broadcast SMS

- Send up to three messages simultaneously
- Send one of two fixed ASCII text messages or configure a custom ASCII text message or custom data message using GPIB

Fixed message 1:

The quick brown fox jumps over the lazy dog

Fixed message 2:

This instrument provides functional testing of broadcast SMS by sending up to three broadcast messages to the device under test. Two fixed messages and a user-defined message are available for selection. The second fixed message spans multiple pages.

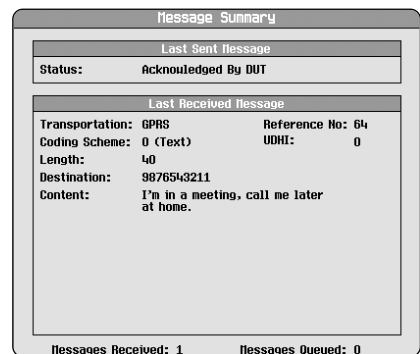

Figure 3. Test your device's SMS performance with configurable MO and MT SMS.

IP Data Connection

- Transfer of IP packet data between a DUT and a network with full PDP context activation
- **Test device's IP packet data functionality:** WAP or Web browsing, FTP throughput rates, serial or USB modem functionality, e-mail, and data downloads to PC
- GSM CS and (E)GPRS PS connections
- Change multislot configurations, coding schemes, power levels, and channel numbers during data transfer
- **Ping:** test set ping of DUT or other device on a network, network ping of test set or device
- Dual transfer mode: simultaneous GSM voice call and (E)GPRS data connection
- Settable primary and secondary DNS server IP address
- Up to four settable DUT IP addresses with independently settable quality of service (QoS) profiles

GSM CS data connection

- Mobile-originated establishment of a CS data connection at 2.4, 4.8, or 9.6 kb/s using a full-rate GSM channel
- Transparent data (raw rate-adapted bits directly to PPP) at 2.4, 4.8, and 9.6 kb/s
- Non-transparent data (using RLP layer) at 4.8 and 9.6 kb/s
- Full logging of RLP, PPP, and IP layers using WPA

(E)GPRS PS data connection

- Mobile-originated and mobile-terminated establishment of a PS data connection
- **(E)GPRS class B:** page voice and SMS during an active (E)GPRS data transfer
- **(E)GPRS suspend and resume:** active (E)GPRS data transfer suspended upon acceptance of voice or GSM SMS request, then resumed after voice call or SMS is complete
- Full logging of decoded Layer 1 through IP layer with WPA

Trigger Output Functionality

- **Frame trigger outputs:** any combination of every frame, every frame except idle frames, every radio block, every BCH multi-frame, every PDTCH multiframe, or on a specific frame number (once per hyperframe)
- **Protocol event trigger output timing:** protocol events associated with an MS action can provide a trigger when the BS event occurs, when the MS is expected to receive, or when the MS is expected to transmit
- **RLC/RR layer protocol event trigger outputs:** any combination of packet uplink assignment, packet downlink assignment, packet timeslot reconfigure, packet power control and timing advance, and packet immediate assignment messages
- **Upper layer protocol event trigger outputs:** any combination of identity request, attach accept, detach request, request PDP context activation, and PDP context activation accept messages

| Call Setup Screen | | | | | | |
|-----------------------|--|----------------|------------------|-------------|---------------------|--|
| PDP Setup | DUT PDP Context Status | | | | Call Params | |
| DUT PDP Setup ▾ | | | | | BCH Parameters | |
| | <u>IP Address</u> | <u>Context</u> | <u>NSAPI</u> | <u>QoS</u> | | |
| QoS Profile 1 Setup ▾ | 156.141.106.47 | Primary | 5 | Profile 1 | TCH Parameters | |
| | | Primary | ---- | Profile 1 | | |
| QoS Profile 2 Setup ▾ | | Primary | ---- | Profile 1 | PDTCH Parameters | |
| | | Primary | ---- | Profile 1 | | |
| | QoS Profile 2 Setup | | | Value | | |
| QoS Profile 3 Setup ▾ | Override Requested Reliability Class State | | | Off | Handover Parameters | |
| | Override Requested Reliability Class | | | 100 | | |
| | Subscribed Reliability Class (pre R99) | | | 100 | | |
| QoS Profile 4 Setup ▾ | Traffic Class | | | Interactive | | |
| | Traffic Handling Priority | | | 2 | | |
| Close Menu | | | | | Receiver Control | |
| | Active Cell | | Sys Type: GPRS | | | |
| | PDP Active | | Logging: No Conn | | | |
| | IntRef | Offset | L | | | |

Figure 4. Test your device's internet connectivity using CS data.

Integrated GSM and (E)GPRS Functionality

- Switch between GSM, GPRS or EGPRS serving cells
- Switch between data and voice connections without losing camp or attach
- Establish a voice or data connection after initial (E)GPRS attach
- Send SMS while on a voice call
- Send SMS while a PS data connection is active
- Initiate a voice call while a PS data connection is active; data transfer is suspended and resumes after the voice call is terminated
- Dual transfer mode (DTM), including enhanced DTM

GSM Functionality

Mobile station power output level control: meets GSM phase one and phase two power control levels

Traffic channels: TCH/FS-FR, EFR, HR, AFS, and AHS speech modes

Broadcast channel configuration:

- Combined BCH/SDCCH
 - $BCH = FCCH + SCH + CCCH + BCCH + SDCCH / 4 + SACCH / C4$
- Non-combined BCH/SDCCH
 - $BCH = FCCH + SCH + CCCH + BCCH$
 - $SDCCH / SACCH = SDCCH / 8 + SACCH / C8$

SDCCH configuration:

- Settable assignment channel TCH or SDCCH
- SDCCH subchannel settable from 0 to 3
- Destination channel selectable TCH or SDCCH

Signaling protocol setup: FACCH audio speech echo with one-second fixed delay

GPRS Functionality

Multislot classes supported:

1 through 12 plus 30, 31, 32, and 33

Control channels: BCH on timeslot 0 on any ARFCN in any band

Broadcast channel configuration:

- Combined BCH/SDCCH
 - $BCH = FCCH + SCH + CCCH + BCCH + SDCCH / 4 + SACCH / C4$
- Non-combined BCH/SDCCH
 - $BCH = FCCH + SCH + CCCH + BCCH$
 - $SDCCH / SACCH = SDCCH / 8 + SACCH / C8$

Packet broadcast channel configuration: PBCCH + PCCCH + PDTCH + PACCH + PTCCH. PDTCH, PACCH, and PTCCH currently unused

Downlink PDTCH: one, two, three, four or five timeslots on the same PDTCH ARFCN with one or two PDTCH amplitudes settable between 0 and 55 dB below BCH amplitude; amplitudes in adjacent timeslots selectable as off, PRL (power reduction level) one, or PRL two

EGPRS Functionality

Multislot classes supported:

1 through 12 plus 30, 31, 32, and 33

Control channels: BCH on timeslot 0 on any ARFCN in any band

Broadcast channel configuration:

- Combined BCH/SDCCH
 - BCH = FCCH+SCH+CCCH+BCCH+SDCCH/4+SACCH/C4
- Non-combined BCH/SDCCH
 - BCH = FCCH+SCH+CCCH+BCCH
 - SDCCH/SACCH = SDCCH/8 + SACCH/C8

Packet broadcast channel configuration: PBCCH + PCCCH + PDTCH + PACCH + PTCCH. PDTCH, PACCH, and PTCCH currently unused

Downlink PDTCH: one, two, three four or five timeslots on the same PDTCH ARFCN with one or two PDTCH amplitudes user-settable between 0 and 42 dB below BCH amplitude; amplitudes in adjacent time slots user-selectable as off, PRL (power reduction level) one or PRL two

GSM TCH parameters

- Settable downlink TCH power including power in adjacent bursts, uplink band, channel number, and power level
- Channel modes of FR,EFR, AMR, and HR, plus HR subchannel of 0 or 1
- Settable uplink timeslot of 0 to 7
- Settable timing advance of 0 to 63
- Mobile loopback of off, type A, type B, or type C as defined in ETSI 04.14 or 3GPP 44.014
- Downlink TCH speech types of none, echo, 300 Hz sine, 1 kHz sine, 3 kHz sine, PRBS-15, multi-tone or custom
- Repeated SACCH, off, on request, continuous
- Repeated FACCH, off, on

GPRS and EGPRS PDTCH parameters

- Settable downlink PDTCH power including power in adjacent bursts, uplink band, channel number and power level
- GPRS coding schemes of CS-1, CS-2, CS-3 or CS-4
- EGPRS DL modulation coding schemes of MCS-1 through MCS-9
- EGPRS UL modulation coding schemes of MCS-1 through MCS-9
- GPRS multislot configurations of 1x1, 1x2, 1x3,1x4, 2x1, 2x2, 2x3, 2x4, 3x1, 3x2, 4x1, 4x2, 5x1, (downlink x uplink)
- Selection of which contiguous DL bursts to loop back on the uplink with connection type GPRS ETSI type B or EGPRS SRB loopback
- Selection of which UL burst to use for RF measurements

Cell operation parameters

- BCH type, combined or non-combined
- Dual transfer mode, on or off
- Enhanced DTM, on, or off
- Extended uplink TBF, on or off
- Extended uplink TBF NODATA state on or off
- MSC-SGSN revision
 - Release 98 or older
 - Release 99 onwards
- Mobile DTx state, on or off
- Packet control Ack type, RLC/MAC Ctrl or four access bursts
- Persistent attach state, on or off
- PBCCH, on or off
- PRACH length of 8 or 11
- Band indicator of DCS or PCS
- SACCH LAPDm format B or B4
- BEP period, settable from 0 to 10
- Block sequence countdown value max, settable from 0 to 15
- C2 penalty time, settable from 0 to 31
- C2 temporary offset, settable from 0 to 7
- Cell bar access, 0 or 1
- Cell bar qualify, 0 or 1
- Cell reselect hysteresis, settable from 0 to 7 (0 to 14 dB)
- Cell reselect offset, settable from 0 to 63 (0 to 126 dB)
- DRX timer max, settable from 0 to 7 (0 to 64 ms)
- IMSI attach state, on or off
- MS Tx power max CCH (GSM), settable from 0 to 31
- MS Tx power max CCH (GPRS), settable from 0 to 31
- MS Tx power max CCH DCS1800 offset, settable from 0 to 3
- Multiband reporting, settable from 0 to 3
- N avg I, settable from 0 to 15 (1.00 to 181.02)
- PC measurement channel, 0 or 1
- Rx lev access min, settable from 0 to 63 (from < -100 dBm to > -48 dBm)
- T avg T, settable from 0 to 25 (0.17 to 965.44 mframes)
- T avg W, settable from 0 to 25 (0.17 to 965.44 mframes)
- GSM 450 MHz, GSM 480 MHz, GSM 750 MHz, T_GSM-810, GSM 850 MHz, PGSM 900 MHz, EGSM 900 MHz, RGSM 900 MHz, DCS 1800 MHz, PCS 1900 MHz bands
- GSM MS and BS origination
- GSM MS and BS release
- (E)GPRS mobile-initiated attach and detach
- (E)GPRS network-initiated detach
- (E)GPRS packet data transfers on uplink and downlink
- Intra-cell channel assignments
- Inter-cell handovers between all bands
- BA table with 16 settable neighbor cells

Measurement report parameters

- Report type: normal, enhanced
- Reporting rate: normal, reduced
- NCC permitted settable from 0 to 255
- Network control order, settable 0, 1, or 2
- Network control non-DRX period, settable from 0 to 7 (0.00 to 1.92 s)
- Network control reporting period (idle), settable from 0 to 7 (0.48 to 61.44 s)
- Network control reporting period (transfer) settable from 0 to 7 (0.48 to 61.44 s)
- Multiband reporting 0 to 3
- Serving band reporting 0 to 3
- SCALE_ORD: 0 to 2
- 3G measurement parameter: exclude, include
- 3G search priority: off, on
- FDD measurement parameter: exclude, include
- FDD reporting quality: 0 to 1
- FDD reporting offset: 0 to 7
- FDD reporting threshold: 0 to 7
- FDD multi-RAT reporting: 0 to 3
- FDD Q min: 0 to 7
- FDD GRPS Q offset: 0 to 15
- Q search I: 0 to 15
- Q search C initial: 0, 1
- Q search C: 0 to 15
- Q search P: 0 to 15

Cell identification

- Cell identity, settable from 0 to 65535
- Three-digit MNC off or on in PCS 1900 MHz band
- Settable MCC, MNC, LAC, RAC, NCC, and BCC
- Tx level FACCH signaling on or off
- Guard period length of 9 or 10
- Uplink frame segmentation of asymmetric or symmetric

Paging parameters

- Paging IMSI, settable
- Paging identity type, IMSI or TMSI
- Paging TMSI, settable
- TMSI assignment, on or off
- Paging mode, normal or reorg
- Paging multiframe, settable from 2 to 9
- Repeat paging, on or off
- Call originate timeout, settable from 1 to 999 s

Handover setup

- GSM traffic band, traffic channel, timeslot, channel mode, half-rate speech subchannel, MS Tx level
- GPRS traffic band, traffic channel, coding scheme, multislot configuration, P0 (power reduction reference), MS Tx level burst 1, MS Tx level burst 2, MS Tx level burst 3, MS Tx level burst 4, MS Tx level burst 5, uplink state flag (USF), DTM CSMS Tx level
- EGPRS traffic band, traffic channel, downlink modulation coding scheme, uplink modulation coding scheme, multislot configuration, PO, MS Tx level burst 1, MS Tx level burst 2, MS Tx level burst 3, MS Tx level burst 4, MS Tx level burst 5, uplink state flag (USF), DTM CSMS Tx level

Calling party number (Caller ID)

- Include/exclude
- Settable calling party number
- **Number type:** unknown, international, national, network, dedicated
- **Number plan:** unknown, ISDN/telephony, data, telex, private, national
- **Presentation indicator:** allowed, restricted, number not available
- **Screening indicator:** user no screen, user verify pass, user verify fail, network

DUT information

- International mobile subscriber identity (IMSI)
- International mobile equipment identity (IMEI) (when selected)
- GPRS multislot class
- EGPRS multislot class
- Called number
- GPRS DTM multislot class
- EGPRS DTM multislot class

Counters reported

- Page count
- RACH count
- PRACH count
- Corrupt burst count
- Decode error count
- Missing burst count
- DUT IP Tx packet and byte counts
- DUT IP Rx packet and byte counts

Errors reported

- Burst timing error
- BLER (block error rate)
- USF BLER (assigned)
- USF BLER (unassigned)

Neighbor cell reports

- Channel number
- Base station color code (BCC)
- Rx level
- Network color code (NCC)

Last location information reported

- Location area code (LAC)
- Mobile country code (MCC)
- Mobile network code (MNC)

SACCH reports

(on a GSM voice call)

- Timing advance
- Tx level
- Rx level (full)
- Rx level (sub)
- Rx qual (full)
- Rx qual (sub)

PACCH reports

(on a EGPRS data connection)

- C value
- GMSK and 8PSK mean BEP
- GMSK and 8PSK variation coefficient
- I level, GMSK and 8PSK BEP for timeslots 0 to 7

PACCH reports

(on a GPRS data connection)

- C value
- Rx qual
- Signal variance
- I level for timeslots 0 to 7

Network control measurement reports

- Network control mode
- Rx level
- I level

General measurement reports

- Up to six neighbor cell reports for RAT, (U)ARFCN, NCC, BCC, SC, and report quantity
- Up to 16 GSM neighbors for ARFCN, BCC, NCC, and RxLev
- Up to 13 3G FDD neighbors for UARFCN, SC, and report quantity

(E)GPRS Layer 1 protocol control

- Downlink corruption on or off
- Sequence length settable between 1 and 2048 blocks
- Blocks in sequence to corrupt settable between 1 and 2048
- Corruption applied to burst(s) 1, 2, 3, 4, and/or 5
- First corrupted symbol settable between 1 and 148
- Number of symbols to corrupt settable between 1 and 148
- Corruption pattern selectable as all zeros, all ones, or invert

RLC/MAC protocol control

- **Retransmission MCS switching:** on or off
- **Retransmissions before MCS switch:** settable from 1 to 500
- **Downlink resegmentation:** on or off
- **NACK good blocks:** off or settable from 0.1 to 100%
- **Window size:** selectable from minimum or maximum
- **EGPRS supplementary polling (ESP):** selectable from (4 sub-bullets), 00-RRBP field invalid (no polling), 01-RRBP field valid, extended Ack/Nack type FPB, 10-RRBP field valid, extended Ack/Nack type NPB, 11-RRBP field valid, NPB with meas reports
- **MAC control:** medium access control mode dynamic, dynamic (auto), fixed or extended dynamic, settable USF value, settable assigned USF value of 0 to 100 percent, selectable unassigned USF, random, or manual
- **Handover control:** packet time-slot reconfigure off or on, packet power timing advance off or on
- **Block poll rate:** settable value from one to 32
- **Temporary block flow control**
 - Frame start position: relative, absolute, immediate
 - Delayed downlink TBF, settable from 0.1 to 30 s
 - Extended uplink TBF, settable from 0.1 to 30 s
 - TBF re-establishment: on, off
- **Uplink packet ACK/NACK interval (GPRS):** 1 to 63
- **Uplink packet ACK/NACK interval (EGPRS):** 1 to 1023

- **RLC/MAC header:** off or on in GPRS BCH+PDTCH and EGPRS BCH+PDTCH operating modes
- **Relative reserved block period (RRBP):** settable from 0 to 3
- **Uplink frame segmentation:** asymmetric or symmetric
- **EGPRS link quality measurement modes:** no measurements (00), interference measurements for timeslots 0-7 (01), bit error probability (BEP) measurements for allocated timeslots (10) or interference (alternate timeslots 0-3 and 4-7), and BEP (11) as defined in ETSI 05.08 or 3GPP 45.008

LLC protocol control

- **FCS for BLER:** valid or corrupt
- **Payload patterns in ETSI B or for BLER with corrupt FCS:** all zeros, all ones, alternate bits, alternate pairs, alternate quads, PRBS-15, fixed 2B (hex), custom, GMM information for BLER

GMM protocol control

- **Attach accept:** selectable GMM cause, reject IMSI for non-GPRS services off or on
- **Attach reject:** selectable GMM cause, reject all attach attempts off or on
- **Detach request:** selectable GMM cause
- **Identity request:** IMSI, IMEI, IMEISV, TMSI

SM protocol control

- **Activate PDP context accept:** override requested reliability class off or on with selectable value, selectable subscribed reliability class, includes acknowledged LLC
- **Activate PDP context reject:** selectable SM cause

E-OTD and A-GPS Functionality

- Partially customizable RRPL layer
- Configure and send measure position request and assistance data messages from the test set
- Ensure assistance data messages are acknowledged by the DUT
- Receive and display RRLP protocol error messages
- Retrieve parameters from the last measure position response message from the DUT
- GPIB access only
- The ESG series of RF signal generators and E4406A VSA transmitter tester also have E-OTD and A-GPS functionality that can be used with the 8960 test set
- ULTS UMTS location test system for A-GPS performance analysis of GSM/(E)GPRS mobile devices available through Spirent Communications at www.spirentcom.com
- Refer to *Configuring the GSM/GPRS Lab Application for E-OTD Performance Testing* application note (literature number 5988-8458EN) at www.agilent.com/find/e6701d

WPA Logging Software

Allows real-time protocol logging of GSM, GPRS, EGPRS, W-CDMA, and cdma2000 messages as well as post-capture analysis of signaling. Please refer to the E6584A Wireless Protocol Advisor data sheet at www.agilent.com/find/e6584a

Technical Specifications

These specifications apply to the following:

- E6701E GSM/GPRS Lab Application, revision E.01.XX operating on E5515C mainframes supplied after November 2006
- E6701T GSM/GPRS Special High Data Rate Lab Application, revision T.02.xx operating on E5515C mainframe with Special High Data Rate hardware supplied after November 2006
- E6704A EGPRS Lab Application Extension

Depending on exact configuration, earlier E5515C and E5515B instruments may require hardware upgrade to obtain certain features and capability. Features which may require hardware upgrades include: spectrum monitor, E6704A EGPRS lab application extension, and RF out only port.

CAUTION: Loading an application onto your E5515 test set that is not compatible with your E5515's hardware revision can cause your E5515 to lock up. For information on application/E5515 compatibility go to <http://www.agilent.com/find/E5515> and select the relevant link (either E5515B Release Notes or E5515C Release Notes.) Always refer to this information before loading an application.

The E6701T Lab Application specified performance for all parameters communicated in this data sheet and the referred to E1968A data sheet is 25 °C ±5 °C. The 6701T operating conditions are 0 to 35 °C.

All other technical specifications and operating modes are included in the E1968A GSM/GPRS/EGPRS mobile test application data sheet on the Web at www.agilent.com/find/e1968a

Transmitter and receiver measurement specifications

The time until a measurement times-out and returns control to the user can be set independently for each measurement. All measurements return a measurement integrity result indicating the accuracy and usefulness of each measurement's results.

Frequency coverage and amplitude range

Unless otherwise noted, all specifications apply to frequencies of 450 to 496 MHz, 700 to 960 MHz, and 1.7 to 1.99 GHz, signals with peak input power at the test set's RF IN/OUT not higher than +37 dBm and temperatures of 0 to +55 °C. Input signal transmit power (defined as the average power over the useful part of the burst) at the test set's RF IN/OUT must be within ±3 dB of the test set's expected power for warranted performance.

All EGPRS features and capabilities are enabled though optional E6704A license.

Receiver measurement specifications

GSM bad frame indication (BFI) measurement

Standards reference: bad frame indication on TCH/FS as per 3GPP 51.010-1, section 14.1.1

Types of signals measured: GSM carrier (TCH/FS) modulated with random data sent at 11 dB above the reference sensitivity level, SACCH and silence descriptor (SID) frames sent at 20 dB above the reference sensitivity level with the mobile configured to signal bad frames and using discontinuous transmission (DTX)

Minimum input level: all uplink signals at test set's RF IN/OUT must have transmit power ≥ -30 dBm

Mobile loopback: type A as defined in ETSI 04.14 or 3GPP 44.014

Speech frames delay: settable between 1 and 15

Numerical results: undetected bad frame rate, number of frames sampled, number of SIDs sent, number of undetected bad frames, number of SIDs marked as BFI

Multi-measurement capabilities: 1 to 999,999 frames sampled

Concurrency capabilities: GSM BFI measurements can be made concurrently with all other measurements

Supplemental characteristics

Measurement resolution:
0.001 percent

AMR in-band frame error (I-FER) measurement data:

- **Standards reference:** reference sensitivity - TCH/AFS-INB as per 3GPP 51.010-1 section 14.2.19, reference sensitivity - TCH/AHS-INB as per 3GPP 51.010-1 section 14.2.20, TCH loop without signaling of erased frames for in-band channel error as per 3GPP 51-010-1 section 5.1.7a
- **Types of signal measured:** reference sensitivity of AMR channel with cycled sequence of CMI and CMC bits
- **Minimum input level:** all uplink signals at test set's RF IN/OUT must have transmit power = -30 dBm
- **Speech frames loopback delay:** settable between 0 and 10
- **Change period:** settable period between codec mode changes, between 1 and 100
- **Numerical results:** I-FER speech frames tested, I-FER ratio, I-FER count, I-FER speech frame delay
- **Multi-measurement capabilities:** 1 to 900,000 frames sampled
- **Concurrency capabilities:** AMR I-FER measurements can be made concurrently with all other measurements except GSM BER or FBER

Supplemental characteristics

Measurement resolution:
0.01 percent

GSM FACCH/F frame erasure rate (FER) measurement

Standards reference: reference sensitivity on FACCH/F as per 3GPP 51.010-1, section 14.2.3

Types of signals measured: count of Layer 2 repeated frames when downlink stimulated with GSM Layer 3 MM information message sent on the FACCH

Minimum input level: all uplink signals at test set's RF IN/OUT must have transmit power ≥ -30 dBm

Mobile loopback: selectable in active cell operating modes as type A, type B, type C, or off

FACCH repetition interval: settable from 120 ms to 1 s

Numerical results: FACCH FER, number of frames erased, number of frames sampled

Multi-measurement capabilities: 1 to 999,999 frames sampled

Concurrency capabilities: GSM FACCH FER measurements can be made concurrently with all other measurements

Supplemental characteristics

Measurement resolution:
0.001 percent

Data throughput monitor

Description: measures instantaneous, peak, and average data rates and the accumulations of all transferred IP packets and bytes

Axis control: settable time span up to 600 seconds, and start and stop data rates

Trace display: over-the-air (OTA) Tx, OTA Rx, IP Tx, and/or IP Rx

Trace markers: one marker settable for each of the four possible traces to display

Freeze display: freeze display for analysis then resume to see cumulative results

Graphical results: line graph of instantaneous data rate versus time

Numerical results: current, average and peak data rates for OTA and IP packets transferred, data rate at marker position, total bytes of data transferred

Historical results: previous 600 seconds of results stored and retrievable via GPIB

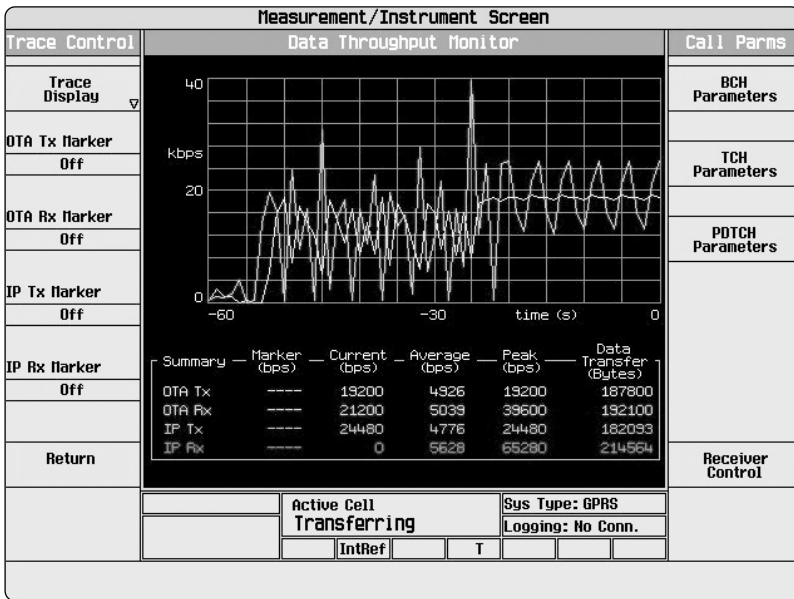

Figure 5. Graphical views of OTA and IP packet throughput help you to test your device.

Test Subscriber Identification Module (SIM) Cards

Test SIM cards are available for purchase from Agilent. Two types are available as follows.

- **Programmed GSM SIM card microsize:** fits most current wireless devices (about 15 x 25 mm), part number 08922-61887
- **Programmed UMTS SIM card microsize:** fits most current wireless devices (about 15 x 25 mm), part number E5515-61286

Ordering Information

For the most up-to-date lab application ordering information, please visit the Agilent site at www.agilent.com/find/8960devicedesign

For more information on ordering test SIM cards, visit the Agilent site at www.parts.agilent.com/

 **Agilent Email Updates****www.agilent.com/find/emailupdates**

Get the latest information on the products and applications you select.

 **Agilent Direct****www.agilent.com/find/quick**

Quickly choose and use your test equipment solutions with confidence.

**www.agilent.com/find/open**

Agilent Open simplifies the process of connecting and programming test systems to help engineers design, validate and manufacture electronic products. Agilent offers open connectivity for a broad range of system-ready instruments, open industry software, PC-standard I/O and global support, which are combined to more easily integrate test system development.

Remove all doubt

Our repair and calibration services will get your equipment back to you, performing like new, when promised. You will get full value out of your Agilent equipment throughout its lifetime. Your equipment will be serviced by Agilent-trained technicians using the latest factory calibration procedures, automated repair diagnostics and genuine parts. You will always have the utmost confidence in your measurements.

Agilent offers a wide range of additional expert test and measurement services for your equipment, including initial start-up assistance onsite education and training, as well as design, system integration, and project management.

For more information on repair and calibration services, go to

www.agilent.com/find/removealldoubt

www.agilent.com

For more information on Agilent Technologies' products, applications or services, please contact your local Agilent office. The complete list is available at:

www.agilent.com/find/contactus

Phone or Fax**United States:**

(tel) 800 829 4444
(fax) 800 829 4433

Canada:

(tel) 877 894 4414
(fax) 800 746 4866

China:

(tel) 800 810 0189
(fax) 800 820 2816

Europe:

(tel) 31 20 547 2111

Japan:

(tel) (81) 426 56 7832
(fax) (81) 426 56 7840

Korea:

(tel) (080) 769 0800
(fax) (080) 769 0900

Latin America:

(tel) (305) 269 7500

Taiwan:

(tel) 0800 047 866
(fax) 0800 286 331

Other Asia Pacific Countries:

(tel) (65) 6375 8100
(fax) (65) 6755 0042
Email: tm_ap@agilent.com

Revised: 09/14/06

Product specifications and descriptions in this document subject to change without notice.

© Agilent Technologies, Inc. 2006, 2007
Printed in USA, January 23, 2007
5989-5147EN



Agilent Technologies