

Products: SMIQ/FSP/FSU/FSQ/NRP/NGMO2

Hints for Fast and Accurate Testing of GSM/EDGE Mobile Phone Power Amplifiers

Application Note

Short measurement time in conjunction with high accuracy and repeatability of results are essential for efficient testing of mobile phone power amplifiers. Power Meter R&S NRP, Signal Generator R&S SMIQ, Spectrum Analyzers R&S FSP/FSU/FSQ and Power Supply R&S NGMO2 offer optimum characteristics such as high accuracy, fast settling speed and short measurement time in programmed mode. This application note concentrates on testing GSM/EDGE mobile phone power amplifiers and shows typical test setups and programming examples for Signal Generator R&S SMIQ and Spectrum Analyzer R&S FSP, benchmark numbers and repeatability results.



Contents

1	Overview	2
2	Typical measurements and test setups	2
	Test Setup.....	2
3	Fast Restore mode for minimum setup time of Signal Generator SMIQ	4
	Example	5
4	List Mode for short measurement time with Spectrum Analyzer.....	6
	Level measurement	6
	Programming examples.....	7
5	Gated List Mode for shortest averaging time at pulsed measurements with Spectrum Analyzer.....	9
	Example	10
	Programming example for Modulation Spectrum at $\pm 200/400\text{kHz}$.	11
6	Trace readout for gain slope measurements	12
	Programming example for spectrum analyzer	12
7	Modulation Error measurement.....	13
	Programming example.....	13
8	Literature	14
9	Additional Information	14
10	Ordering information	15

1 Overview

Testing is one of the more expensive processes in production lines of consumer electronics such as mobile radio power amplifiers. Short measurement time in conjunction with high accuracy and repeatability of results are therefore essential to achieve an high throughput at low cost.

Power Meter R&S NRP, Signal Generator R&S SMIQ, Spectrum Analyzers R&S FSP/FSU/FSQ and Power Supply R&S NGMO2 offer optimum characteristics such as high dynamic range and accuracy, fast settling speed and short measurement time in programmed mode. This application note concentrates on testing GSM/EDGE mobile power amplifiers and shows typical test setups. By means of some programming examples for SMIQ and FSP (FSU/FSQ) it is demonstrated how to achieve minimum measurement time for relevant measurements on GSM/EDGE mobile radio power amplifiers. Benchmarks numbers in conjunction with repeatability results (standard deviation σ) are presented as well.

Programming examples are done by means of a command sequencer (GDE) which allows the measurement of execution times for each command as well as the calculation of repeatability of results [7], page 17.

2 Typical measurements and test setups

Test Setup

A typical test setup for measuring mobile power amplifiers is shown in figure 1. Signal Generator SMIQ feeds the device under test (DUT) via a lowpass filter – to suppress its own harmonics - and a directional coupler with an appropriate GSM/EDGE modulated RF signal. (For a multi-band amplifier which has to cover frequencies in the range 800 to 1900 MHz two lowpass filters are necessary).

Testing GSM/EDGE mobile phone power amplifiers

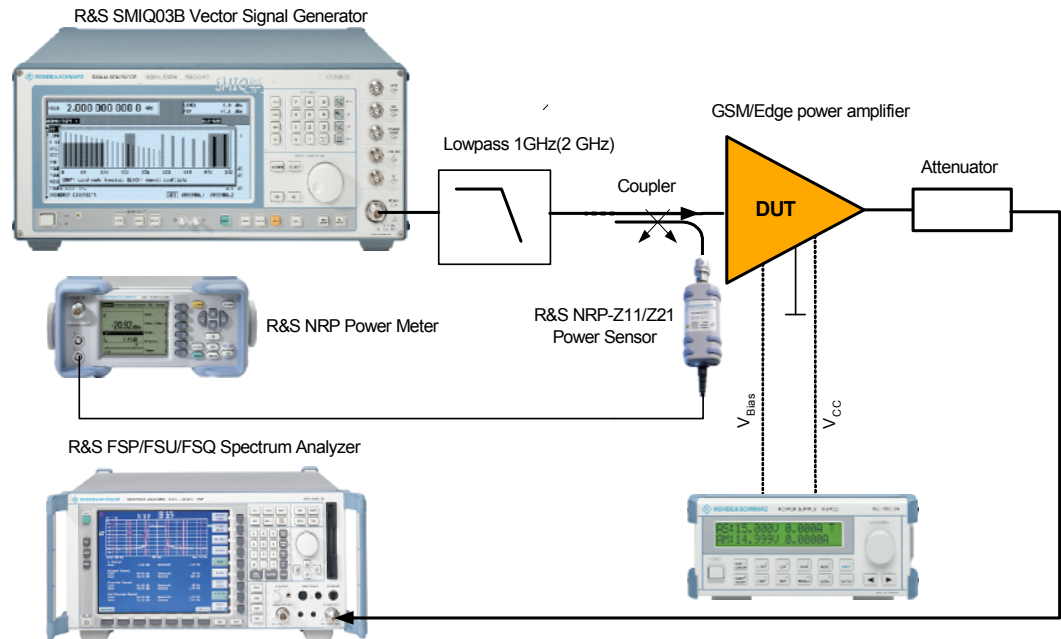

Figure 1: Typical test setup for testing GSM/EDGE mobile power amplifiers

The input signal power is measured by an R&S NRP power meter and an NRP-Z11/Z21 power sensor connected to the coupling branch of the coupler. The DUT's output is connected via a power attenuator to an R&S Spectrum Analyzer FSP/FSU or FSQ. Power supply R&S NGMO2 delivers the supply voltages V_{CC} and V_{BIAS} to the DUT.

Trigger Out 1 of the SMIQ, which delivers a frame trigger in GSM/EDGE mode, is used to synchronize all instruments.

Beside measuring input power, the NRP power meter with NRP-Z11/Z21 power sensor can be used to calibrate the total setup (path losses) for minimum measurement uncertainties. Also the spectrum analyzer's absolute measurement uncertainty can be improved by correcting its indication level to the indication of the power meter. This can be done within a calibration run by connecting the power sensor instead of the spectrum analyzer at the same input level (preferably at the nominal output power level of the DUT). The difference of the power measured by the power meter and that of the spectrum analyzer is used as a correction factor (Reference Level Offset) at the analyzer.

As an alternative to the proposed test setup of figure 1, instead of the NRP power meter, the spectrum analyzer FSP/FSU/FSU with FS-K9 option can be used to control the NRP-Z11/Z21 power sensor. However, triggering of the power sensor then cannot be provided.

Typical measurements using the Spectrum Analyzer at the output of the amplifier are:

- power measurement (and in conjunction with input power, gain measurement)
- adjacent channel power measurement (modulation spectrum in the GSM/EDGE case)
- harmonics k2/k3 in CW mode (bursting CW in GSM/EDGE case)

Testing GSM/EDGE mobile phone power amplifiers

- Gain slope (variation of output power when varying the dc voltage at the amplifiers bias pin)
- modulation error (EVM)

For the GSM/EDGE case all these measurements are to be carried out in burst mode, so only some of the GSM time slots are on.

Additionally DC voltages and currents have to be measured (e.g. for efficiency calculation) which can be done by the NGMO2 power supply plus additional voltmeters. DC voltage and current measurement is not covered by this application note.

3 Fast Restore mode for minimum setup time of Signal Generator SMIQ

When testing power amplifiers, the signal generator that delivers the DUT's input signal has to be switched between different RF frequencies and levels. Also the modulation has to be switched on and off e.g. to measure the harmonics which are to be measured using a CW input signal.

Switching between different frequencies and levels can be done very fast within about a few ms with the SMIQ.

However switching modulation off and on with the SMIQ normally requires a calculation time of several 100 ms in the EDGE modulation case and even more for e.g. 3GPP Standard modulation (see execution times of commands that follows the *SOUR:GSM:STAT ON* command in the programming example below).

Using the *Fast Restore* mode for the SMIQ signal generator switching time is reduced to only 4 ms.

The needed frequencies and levels are to be stored in both modulated and un-modulated states in a pre-configuration block of the remote control program. During the actual measurement sequence these pre-stored settings are recalled. See also [5] for further information.

Testing GSM/EDGE mobile phone power amplifiers

GPIB Commands

:SYSTEM:SSAVE 1 ... n (n being the number of available memory locations)

Saves the current device setting at the indicated memory location

:SYSTEM:SRESTore 1 ... n (n being the number of available memory locations)

Loads a device status that was stored using the :SYSTEM:SRESTore command (Restore).

Example

Within the test program, a test signal is needed at a certain power level (0 dBm), both modulated and un-modulated at 4 frequencies: 824 MHz, 915 MHz, 1710 MHz and 1910 MHz. The modulated signal should contain 2 active slots (slot 0 and slot 1 on), both EDGE modulated.

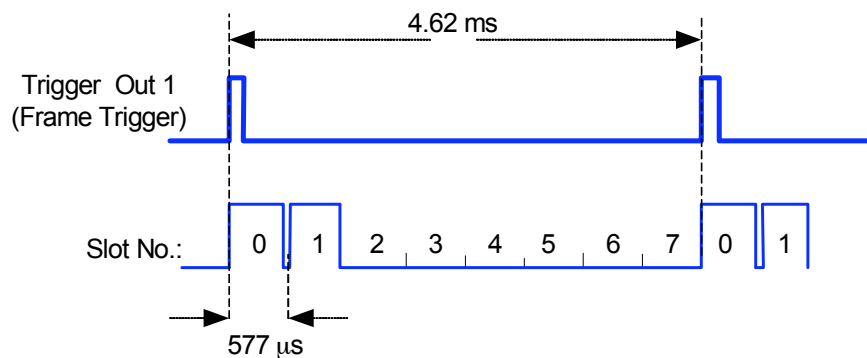

Figure 2: GSM/EDGE timing, slot 0 and slot 1 active

The following sequence of GPIB commands (including comments and numbers of execution time) shows how to do it in a time-efficient way.

Preconfiguration Block

action	command	exec. time
set frequency	SOUR:FREQ 0.824GHz	6 ms
set max peak output level	SOUR:POW 10	17 ms
table mode	OUTP:AMOD FIX; :SOUR:POW:ALC:SEAR OFF; :SOUR:POW:ALC OFF	12 ms
set wanted output level	SOUR:POW 0	4 ms
switch GSM mode on	SOUR:GSM:STAT ON	193 ms
slot 0:EDGE modulation	SOUR:GSM:SLOT0:Type EDGE	243 ms

Testing GSM/EDGE mobile phone power amplifiers

```

slot 0: full level          |SOUR:GSM:SLOT0:Lev FULL          |          |242 ms
slot 1:EDGE modulation    |SOUR:GSM:SLOT1:Type EDGE        |          |244 ms
slot 1: full level        |SOUR:GSM:SLOT1:Lev Full         |          |240 ms
slot 1: TSC 0             |SOUR:GSM:SLOT1:TSC:SEL TO       |          | 5 ms
set frequency              |SOUR:FREQ 1910MHz                |          | 5 ms
Save EDGE Signal 1910 MHz |SYSTEM:SSAV 8                    |          | 3 ms
set frequency              |SOUR:FREQ 1710MHz                |          | 7 ms
Save EDGE Signal 1710 MHz |SYSTEM:SSAV 6                    |          | 3 ms
set frequency              |SOUR:FREQ 0.915GHz               |          | 5 ms
Save EDGE Signal 915 MHz  |SYSTEM:SSAV 4                    |          | 2 ms
set frequency              |SOUR:FREQ 0.824GHz               |          | 5 ms
Save EDGE Signal 824MHz   |SYSTEM:SSAV 2                    |          | 3 ms

Modulation off            |SOUR:MOD:STAT OFF                |          | 9 ms
set frequency              |SOUR:FREQ 1910MHz                |          | 6 ms
Save CW Signal 1910 MHz   |SYSTEM:SSAV 18                   |          | 2 ms
set frequency              |SOUR:FREQ 1710MHz                |          | 4 ms
Save CW Signal 1710 MHz   |SYSTEM:SSAV 16                   |          | 2 ms
set frequency              |SOUR:FREQ 0.915GHz               |          | 5 ms
Save CW Signal 915 MHz    |SYSTEM:SSAV 14                   |          | 3 ms
set frequency              |SOUR:FREQ 0.824GHz               |          | 4 ms
Save CW Signal 824MHz     |SYSTEM:SSAV 12                   |          | 2 ms
Modulation on             |SOUR:MOD:STAT ON                 |          |340 ms

```

Measure block:

action	command	exec. time
Switch to modulated 824MHz	SYST:SRES 2	4 ms
...		
Switch to CW 824MHz	SYST:SRES 12	4 ms
...		
Switch to modulated 915MHz	SYST:SRES 4	4 ms
...		
Switch to CW 915MHz	SYST:SRES 14	4 ms
...		
Switch to modulated 1710MHz	SYST:SRES 6	4 ms
...		
Switch to CW 1710MHz	SYST:SRES 16	4 ms
...		
Switch to modulated 1910MHz	SYST:SRES 8	4 ms
...		
Switch to CW 1910MHz	SYST:SRES 18	4 ms

4 List Mode for short measurement time with Spectrum Analyzer

Level measurement

Quickest level measurement in time domain over frequency is achieved by means of the "List Mode" [2], [3] or [4]: chapter SENSE:LIST Subsystem. A predefined list of measurement points each with an individual set of frequency, reference level, attenuator setting (electronic and mechanical), filter type/bandwidth can be loaded and run with a minimum execution time. When measuring mobile power amplifiers the "List Mode" is optimum for all power measurements, measurement of harmonics and as well Adjacent Channel power.

Testing GSM/EDGE mobile phone power amplifiers

Only two commands are necessary to program the "List Mode":

1. `[SENSe<1|2>:]LIST:POWer:SET <PEAK meas>,<RMS meas>,<AVG meas>,<trigger mode>,<trigger slope>,<trigger offset>,<gate length>`

This command defines the constant settings for the list during multiple power measurement. Parameters `<PEAK meas>`, `<RMS meas>` and `<AVG meas>` define which measurements are to be performed at the same time at the frequency point. Correspondingly, one, two or three results per frequency point are returned for the `SENS:LIST:POW?` command.

2. `SENSe:LIST:POWer? <analyzer freq>,<ref level>,<rf att>,<el att>,<filter type>,<rbw>,<vbw>,<meas time>,<trigger level>,...`

This command sets up the individual settings for each list point (frequency, reference level, attenuation, electronic attenuation, filter type, resolution and video bandwidth, measurement time and trigger level) and query the results. Up to 200 list points are possible. The result is an output list whose length is dependent on the number of points and the constant settings (one, two or three results per points).

Programming examples

Programming sequence 1 to measure the power of slot No. 1 of an EDGE Signal with active slots No. 0 and No. 1.

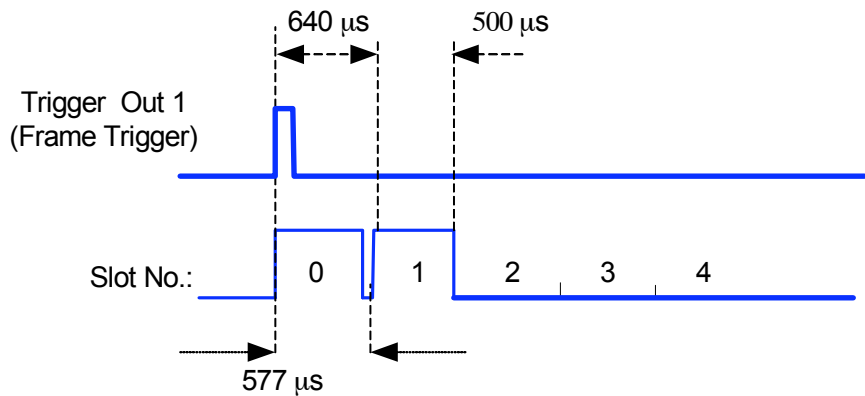

Figure 3: Setting for measuring the power of slot 1

The *Trigger Output 1* of the SMIQ is used as a trigger Signal for the Analyzer:

Action	command	result	exec. time
Set trigger delay to 2 nd slot	<code>SENS:LIST:POW:SET Off,ON,OFF,Ext,Pos,0.64ms,0</code>		9 ms
Query result(power) at 824 MHz	<code>SENS:LIST:POW? 824MHz,18dBm,30dB,Off,NORM,1MHz,1MHz,0.5ms,0</code>	+11,231 dBm	10 ms

Testing GSM/EDGE mobile phone power amplifiers

Programming sequence 2 to measure the Modulation Spectrum at $\pm 200/400$ kHz of slot No. 1:

Trigger Offset (0.995 ms) and sweep time (0.2ms) are set in such a way that the analyzer sweeps during the 2nd slot of an EDGE frame from 50% to 90% of the slot length excluding the midamble (both slot 0 and slot 1 are on in this example).

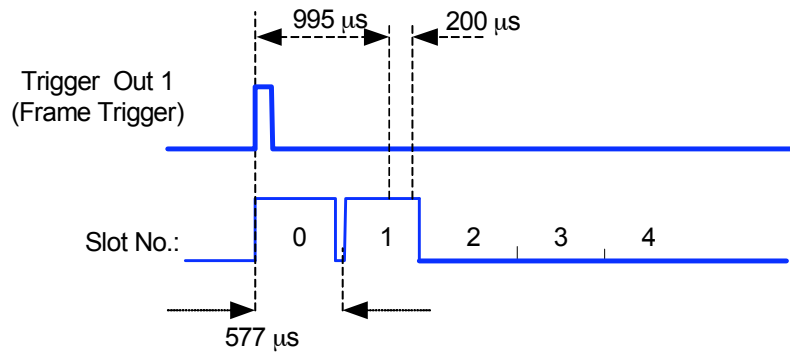

Figure 4: Setting for measuring the modulation spectrum of slot 1

Comment	Command	Result	Exec. time
Set Gate to Mod Spec of 2nd slot	SENS:LIST:POW:SET Off,ON,OFF,Ext,Pos,0.995ms,0		5ms
Query results at list points	SENS:LIST:POW? %MListFile%	5 values	42 ms

Where the MListFile is:

```
824MHz,18dBm,30dB,Off,Norm,30kHz,30kHz,0.2ms,0,
823.8MHz,18dBm,30dB,Off,Norm,30kHz,30kHz,0.2ms,0,
824.2MHz,18dBm,30dB,Off,Norm,30kHz,30kHz,0.2ms,0,
823.6MHz,18dBm,30dB,Off,Norm,30kHz,30kHz,0.2ms,0,
824.4MHz,18dBm,30dB,Off,Norm,30kHz,30kHz,0.2ms,0
```

At typical result after the query results would be (rms powers at center frequency, ± 200 kHz and ± 400 kHz measured with 30 kHz bandwidth):

```
1.55..., -35.24..., -35.7..., -53.656..., -54.92...
```

5 Gated List Mode for shortest averaging time at pulsed measurements with Spectrum Analyzer

To get a better repeatability of results, a measurement over several time slots is necessary e.g. for the adjacent channel power. The optimum method to do this is combining the list mode with time gating. Thus averaging over several bursts can be achieved with a minimum of time overhead. With an appropriate gate setting, the analyzer sweeps at every burst during the set gate length (and with the set trigger delay) until the set sweep time is reached.

Within the following example, to measure the modulation spectrum at $\pm 200 / 400$ kHz the gate delay (for remote control: trigger offset = 0.995 ms) and gate length (0.2 ms) are set in such a way that the analyzer sweeps during the 2nd slot of an EDGE frame from 50% to 90% of the slot length excluding the midamble (both slot 0 and slot 1 are on in this example). The sweep time is set to 8 times the gate length (1.6 ms) to average the result over 8 consecutive frames (by means of the RMS detector used). At the sweep end the analyzer delivers the RMS value of the trace. The repeatability of results is now much better (standard deviation about 0.3 dB compared to about 1.3 dB without averaging). The measurement time increases from 40 ms to 200 ms. For even better repeatability only the sweep time has to be increased to a higher factor, however the measurement time will increase too.

Example

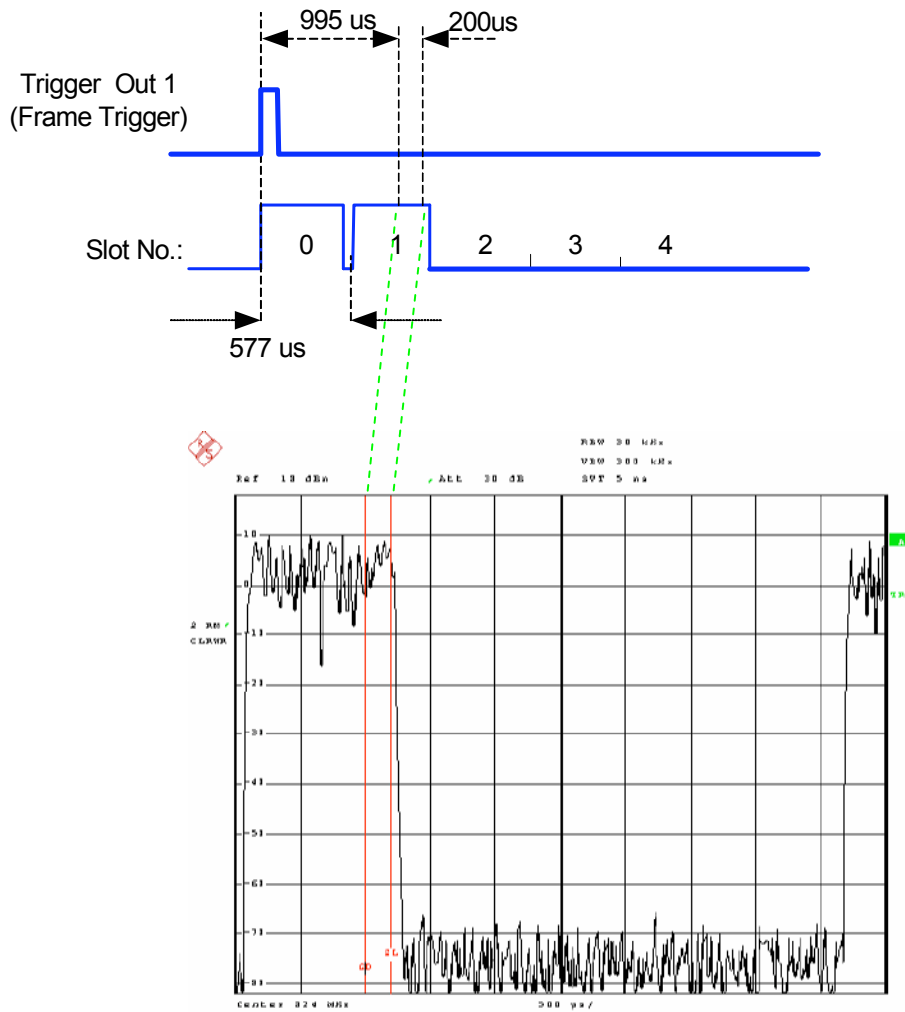

Figure 5: Setting of gate delay (0.995 ms) and gate length (0.2 ms) to measure the modulation spectrum of the 2nd timeslot (50 to 90% of the burst excluding the midamble)

Testing GSM/EDGE mobile phone power amplifiers

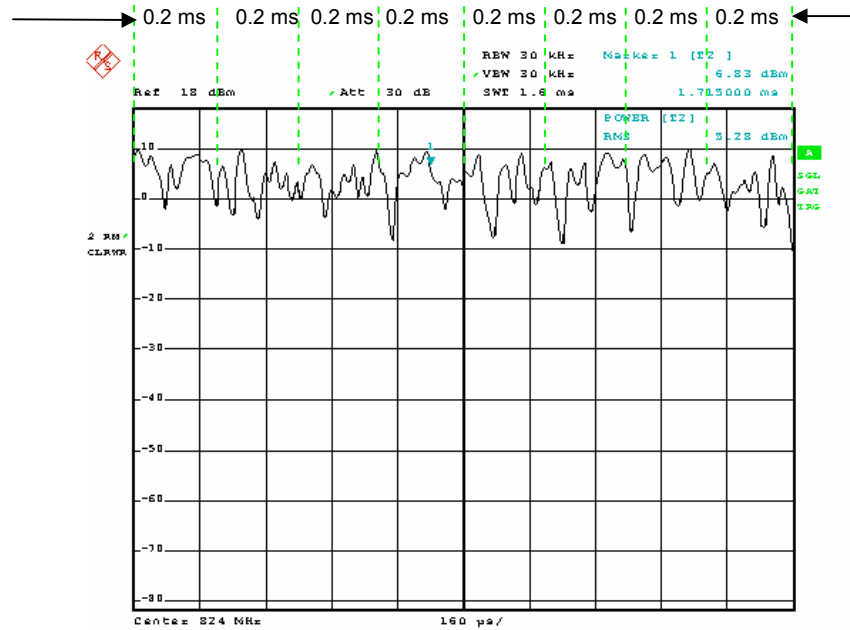

Figure 6: Gated measurement over 8 EDGE frames (50 – 90 % of slot 1) with sweep time 1.6 ms and gate length 0.2 ms. The RMS value of the trace is output.

Programming example for Modulation Spectrum at $\pm 200/400$ kHz

Comment	Command	Result	Exec. time
Set Gate to Mod Spec of 2nd slot	SENS:LIST:POW:SET Off,ON,OFF, Ext,Pos,0.995ms,0.2ms		5 ms
Query results at list points	SENS:LIST:POW? %MListFile1%	5 values	200 ms

Where the MListFile1 is:

```
824MHz,18dBm,30dB,Off,Norm,30kHz,30kHz,1.6ms,0,
823.8MHz,18dBm,30dB,Off,Norm,30kHz,30kHz,1.6ms,0,
824.2MHz,18dBm,30dB,Off,Norm,30kHz,30kHz,1.6ms,0,
823.6MHz,18dBm,30dB,Off,Norm,30kHz,30kHz,1.6ms,0,
824.4MHz,18dBm,30dB,Off,Norm,30kHz,30kHz,1.6ms,0
```

At typical result after the query results would be (RMS powers at center frequency, ± 200 kHz and ± 400 kHz):

```
1.535..., -35.234..., -35.7..., -53.656..., -54.929...
```

6 Trace readout for gain slope measurements

GSM/EDGE mobile power amplifiers usually have a Power Control Connection Pin to control the output power over a wide dynamic range of typically > 30 dB. The dependency of this output power via the control voltage (called gain slope) is an important measurement to be able to control exactly the mobile phone's output power where the amplifier will later be used. Usually the gain slope measurement is performed by applying a ramp function at the amplifier's control input and measuring its output power synchronously.

By use of the fast trace readout function of the FSP/FSU/FSU Spectrum Analyzer the gain slope measurement is done by a minimum amount of time. The transfer of 10001 sweep points (FSU/FSQ, 8001 sweep points with FSP) is done in less than 80 ms. Again the gating function is used to get several ramps for improved repeatability of measurement without any time overhead. In the following programming example the gating time is set to 1 ms and the sweep time to 8 ms. Thus 8 ramps are measured with one shot.

Programming example for spectrum analyzer

Comment	GPIB command	Result	exec. Time
sweep time 8ms	SENS:SWE:TIME 8ms		2 ms
ext. trigger	TRIG:SOURCE EXT		7 ms
sample detector	DET SAMP		2 ms
external gate mode	SWE:EGAT ON		12 ms
edge-triggered mode	SWE:EGAT:TYPE EDGE		2 ms
gate delay 15µs	SWE:EGAT:HOLD 15US		6 ms
gate opening time 1ms	SWE:EGAT:LENG 1ms		4 ms
no. of points 10001	SWE:POIN 10001		2 ms
start sweep	INIT		160 ms
binary format 32 bit	FORM REAL, 32		2 ms
read trace	TRAC? TRACE1	40004 bytes	74 ms

The FSU/FSQ outputs 40004 bytes (4 bytes for every sweep point) when using binary format.

Typical trace readout (graphical representation):

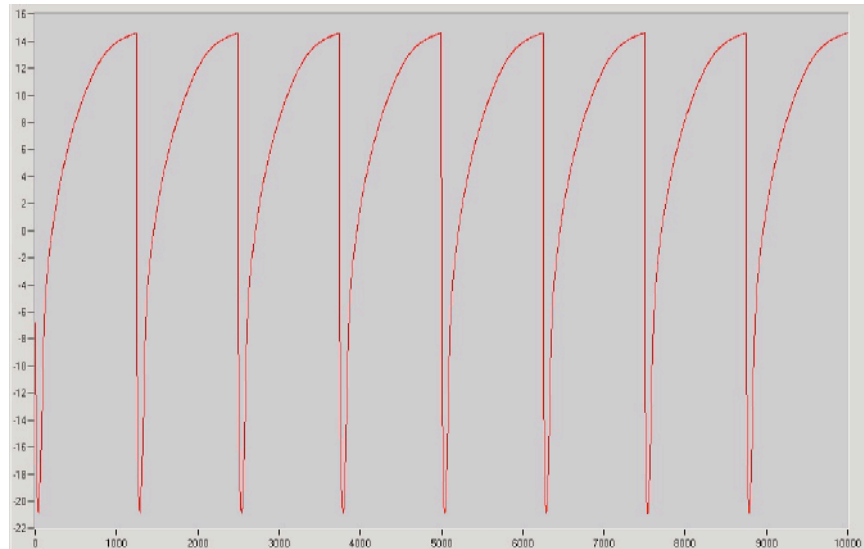

Figure 7: Graph of typical trace readout of gated measurements over 8 successive power rampings (power in dBm)

7 Modulation Error measurement

Switching from normal Spectrum Analyzer Modus to the GSM/EDGE personality to measure the modulation accuracy is a little time consuming (about 250 ms for the first result, only about 85 ms for each following result) and should be done as little as possible (preferably only once). In the following you will find a programming example to measure the modulation error at 4 extreme GSM/EDGE band frequencies in an optimum way.

Programming example

Comment	Instrument	GPIB Command	Result	Exec. time
Switch GSM personality on	Analyzer	INST M GSM		73 ms
Mod. Accuracy	Analyzer	CONF: BURST: MACC		76 ms
(no comment)	Analyzer	FREQ: CENT 824MHz		22 ms
Switch to Modulated 824MHz	Generator	SYST: SRES 2		4 ms
Sweep	Analyzer	INIT		66 ms
Query EDGE Mod. Accur. 824MHz	Analyzer	FETC: BURS: MACC: RMS: AVER?	+0,201 %	4 ms
(no comment)	Analyzer	FREQ: CENT 915MHz		22 ms
Switch to Modulated 915MHz	Generator	SYST: SRES 4		3 ms
Sweep	Analyzer	INIT		56 ms
Query EDGE Mod. Accur. 915MHz	Analyzer	FETC: BURS: MACC: RMS: AVER?	+0,198 %	3 ms
(no comment)	Analyzer	FREQ: CENT 1710MHz		11 ms
Switch to Modulated 1710MHz	Generator	SYST: SRES 6		4 ms
Sweep	Analyzer	INIT		55 ms
Query EDGE Mod. Accur. 1710MHz	Analyzer	FETC: BURS: MACC: RMS: AVER?	+0,203 %	3 ms
(no comment)	Analyzer	FREQ: CENT 1910MHz		22 ms
Switch to Modulated 1910MHz	Generator	SYST: SRES 8		3 ms
Sweep	Analyzer	INIT		55 ms
Query EDGE Mod. Accur. 1910MHz	Analyzer	FETC: BURS: MACC: RMS: AVER?	+0,183 %	3 ms

8 Literature

- [1] Operating Manual Vector Signal Generator SMIQ
- [2] Operating Manual Spectrum Analyzer R&S FSP 3/FSP 13/
FSP30/FSP40
- [3] Operating Manual Spectrum Analyzer R&S FSU3/FSU8/FSU 26
- [4] Operating Manual Spectrum Analyzer R&S FSQ 3/FSQ 8/FSQ 26
- [5] Application Note 1GP55: Fast Remote Control for R&S SMIQ Vector
Signal Generator
- [6] Application Note 1MA65: Fast and Accurate Test of Mobile Phone
Boards
- [7] Application Note 1MA61: CDMA2000 Base Station Test with R&S
Equipment

9 Additional Information

Please contact TM-Applications@rsd.rohde-schwarz.com for comments and further suggestions. We can also provide individual programming proposals and benchmarks according to your measurement needs.

10 Ordering information

Vector Signal Generator

R&S SMIQ02B	0.3 ... 2.2 GHz	1125.5555.02
R&S SMIQ03B	0.3 ... 3.3 GHz	1125.5555.03
R&S SMIQ04B	0.3 ... 4.4 GHz	1125.5555.04
R&S SMIQ06B	0.3 ... 6.4 GHz	1125.5555.06
R&S SMIQ03HD	0.3 ... 3.3 GHz	1125.5555.33
R&S SMIQ-Z5	BNC Adapter for rear panel	1104.8555.02
R&S SMIQB11	Data Generator	1085.4502.04
R&S SMIQB20	Modulation Coder	1125.5190.02

Signal Analyzer, Spectrum Analyzer and Options

R&S FSP3	9 kHz ... 3 GHz	1093.4495.03
R&S FSP7	9 kHz ... 7 GHz	1093.4495.07
R&S FSP13	9 kHz ... 13 GHz	1093.4495.13
R&S FSP30	9 kHz ... 30 GHz	1093.4495.30
R&S FSP40	9 kHz ... 40 GHz	1093.4495.40

R&S FSU3	20 Hz ... 3.6 GHz	1129.9003.03
R&S FSU8	20 Hz ... 8 GHz	1129.9003.08
R&S FSU26	20 Hz ... 26,5 GHz	1129.9003.26

R&S FSQ3	20 Hz ... 3.6 GHz	1155.5001.03
R&S FSQ8	20 Hz ... 8 GHz	1155.5001.08
R&S FSQ26	20 Hz ... 26,5 GHz	1155.5001.26

R&S FS-K5	GSM/EDGE Application Software	1141.1496.02
R&S FS-K9	Power Sensor Measurements	1157.3006.02

Power Meter and Options

R&S NRP	Power Meter	1143.8500.02
R&S NRP-Z11	Power Sensor 10 MHz ... 8 GHz	1138.3004.02
R&S NRP-Z21	Power Sensor 10 MHz ... 18 GHz	1137.6000.02

Power Supply and Options

R&S NRP	Power Supply	0192.1500.24
---------	--------------	--------------



ROHDE & SCHWARZ

ROHDE & SCHWARZ GmbH & Co. KG · Mühldorfstraße 15 · D-81671 München · P.O.B 80 14 69 · D-81614 München ·
Telephone +49 89 4129 -0 · Fax +49 89 4129 - 13777 · Internet: <http://www.rohde-schwarz.com>

This application note and the supplied programs may only be used subject to the conditions of use set forth in the download area of the Rohde & Schwarz website.